

Introduction

The MP7720 is a high fidelity 20W Class D audio amplifier designed to operate from a single 24V power supply. There are some applications, however, where the use of symmetric split supplies is preferred. The purpose of this Design Note is to show that with only a few simple modifications, the MP7720 can be made to operate from $\pm 12V$ split power supplies.

Normal Single-Supply Operation

In the *Single Supply Application Circuit*, input and output DC blocking capacitors are required because the amplifier is normally biased at a DC level that is $\frac{1}{2}$ of the supply voltage. The values of the input and output capacitors are dictated by the required low frequency response combined with the input resistance and output load impedance, respectively. A typical value for the input DC blocking capacitor

is $1\mu F$ and a typical output DC blocking capacitor is $1000\mu F$.

Start-up

During initial start-up, the input and output capacitors need to charge up to $\frac{1}{2}$ of the supply voltage. At start-up, the MP7720 sources a current from the SW node, Pin 7, which is used to pre-charge the output capacitor (and input capacitor through the feedback resistor) to the required $\frac{1}{2} V_{DD}$ point. This current is sourced from Pin 7 until the DC voltage at Pin 2 exceeds the reference voltage, which is externally set at Pin 1. When this condition is met, the MP7720's internal control circuitry enables the AAM™ modulation controller and normal Class D operation begins. The $\frac{1}{2}$ supply reference at Pin 1 is typically created with an equal value resistor-divider connected to Pin 1 of the MP7720.

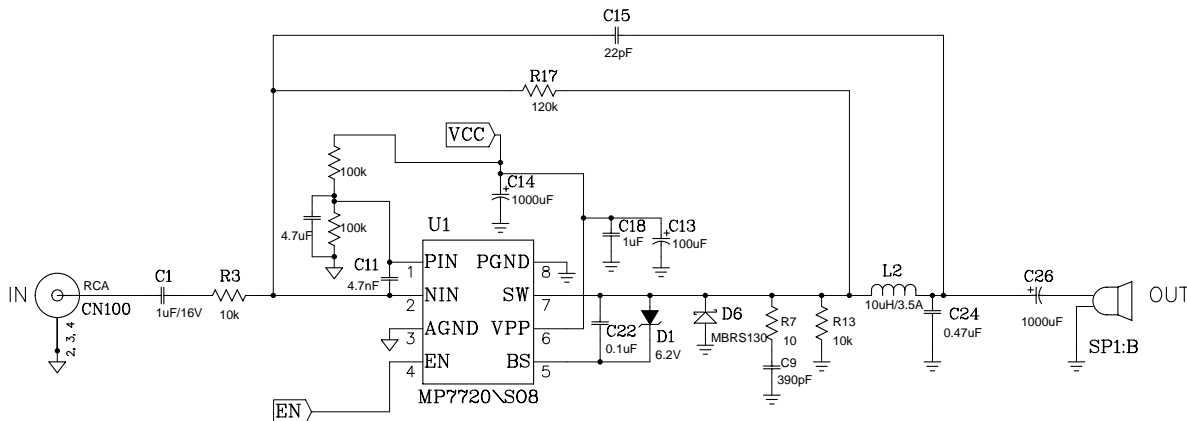

Figure 1—MP7720 Single Supply Application Circuit

Modifications for Split-Supply Operation

For the Split Supply Application Circuit, the input and output capacitors are typically not required, as now the amplifier DC bias point is at 0V or GND. The reference node, Pin 1, is connected to GND. The V_{DD} Pin, Pin 6, is connected to the +12V supply. The GND Pins, Pin 3 and Pin 8, as well as the anode of the output Schottky protection diode are connected to the -12V supply.

Because of the split supply configuration, the Enable voltage at Pin 4 will need to be at a logic-level that is referenced from the $-V_{DD}$ supply. A simple level-shift circuit can be implemented as shown using an inexpensive

transistor, a diode and a few resistors. Additionally, bypass capacitors are needed for the $-V_{DD}$ supply.

Start-up

As with the Single-Supply Application, the MP7720 will wait for the voltage at Pin 2 to exceed the voltage at Pin 1 before switching begins. This of course, will not happen in the normal sense as there is no output capacitor to be charged up to a value slightly above that of the “reference voltage.” However, as soon as an audio input signal is applied, the start-up condition will be met and switching will start immediately – typically within a few microseconds.

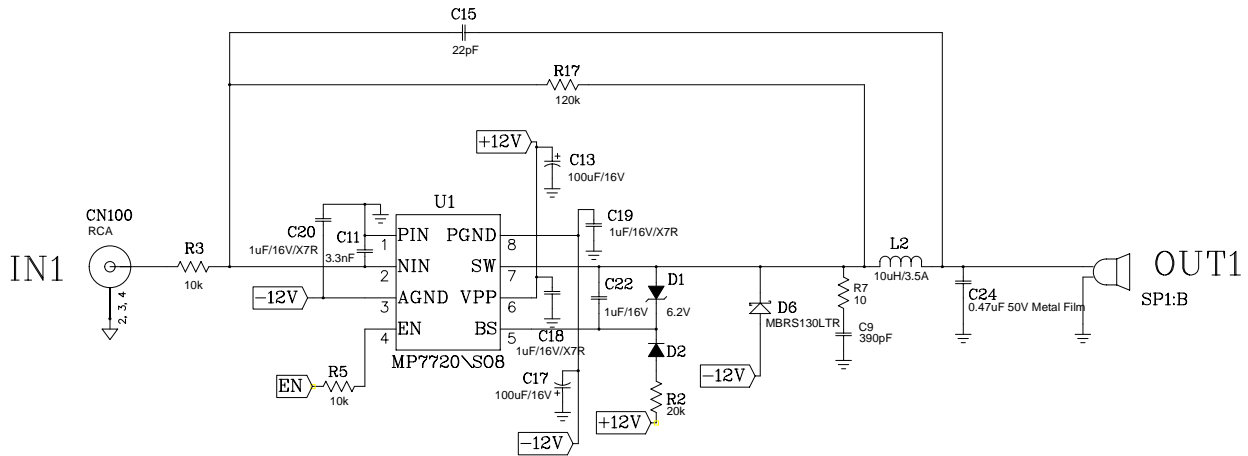

Figure 2—MP7720 Split Supply Application Circuit

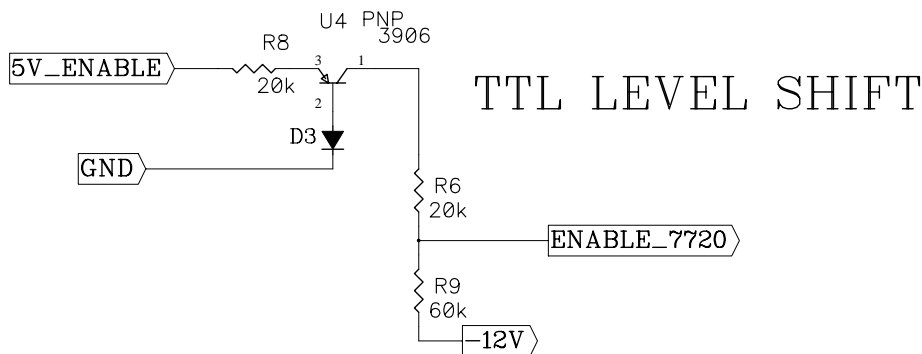

Figure 3—Level Shift Circuit for ENABLE Control

Power Supply Pumping and Supply Caps

Large electrolytic capacitors are required on both +V_{DD} and -V_{DD} to ensure that the power supplies are not “pumped”. Supply pumping is an effect caused by single-ended Class D amplifiers in which current is fed back into the

supply rail during switch transitions. Most power supplies can only source current; thus the main bulk capacitors must be large enough so they can accept this current when it is pumped into the supply node.

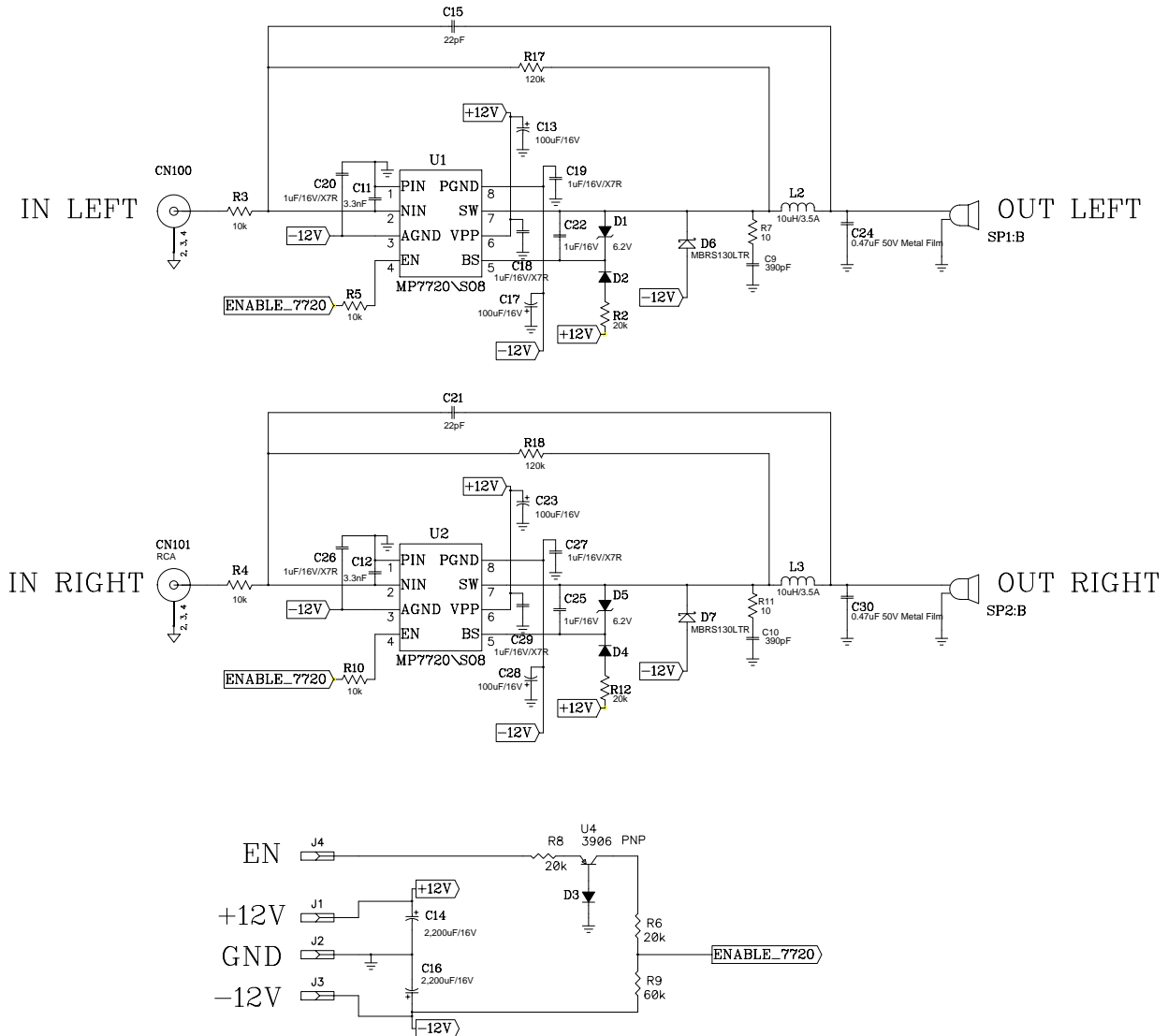

Figure 4—Stereo 20W Split Supply Amplifier

NOTICE: MPS believes the information in this document to be accurate and reliable. However, it is subject to change without notice. Contact MPS for current specifications. MPS encourages users of its products to ensure that third party Intellectual Property rights are not infringed upon when integrating MPS products into any application. MPS cannot assume any legal responsibility for any said applications.