



The Future of Analog IC Technology™

DN0005

3 Output TFT LCD Bias Supply with a Boost Regulator (MP1542)

DESIGN NOTE

Introduction

Many of today's TFT LCD bias supplies are constructed with a boost regulator and external charge pump circuits to reduce product manufacturing costs. The fact that most integrated solutions do not provide flexible power sequencing and output disconnect also makes discrete design more favorable.

Monolithic Power Systems' MP1542 offers an integrated boost regulator/charge pump solution that can provide flexible power sequencing and output disconnect in a competitively priced package.

The MP1542 is a current-mode step-up converter with a 2A, 0.18 Ω internal switch to provide a highly efficient regulation. It operates at 1.3MHz or 700KHz, allowing for easy filtering and low noise. The high switching frequencies and current-mode control allow the use of small components, including low profile inductors and ceramic capacitors. An external compensation pin also gives the user flexibility in setting loop dynamics.

Because the control loop can be easily compensated, even with high loop bandwidth, the output capacitors can have relatively low values and still provide fast and stable transient performance. The high switching frequencies and low ESR of the output ceramic capacitors result in a very low output ripple. Soft-start results in small inrush current and can be programmed with an external capacitor.

The MP1542 also includes under voltage lockout, current limiting and thermal overload protection, preventing damage in the event of an output overload. All these features combined with a low profile 8-pin MSOP package make the MP1542 ideally suited for TFT LCD bias applications.

Figure 1 shows the MP1542 in a bias supply application generating 9V, 26V and -8V outputs. A MOSFET can be added in series with the 26V and -8V outputs to obtain power sequencing and output disconnect as required by and LCD panel. A linear regulator can also be added to the 26V and -8V outputs if tighter load regulation is required.

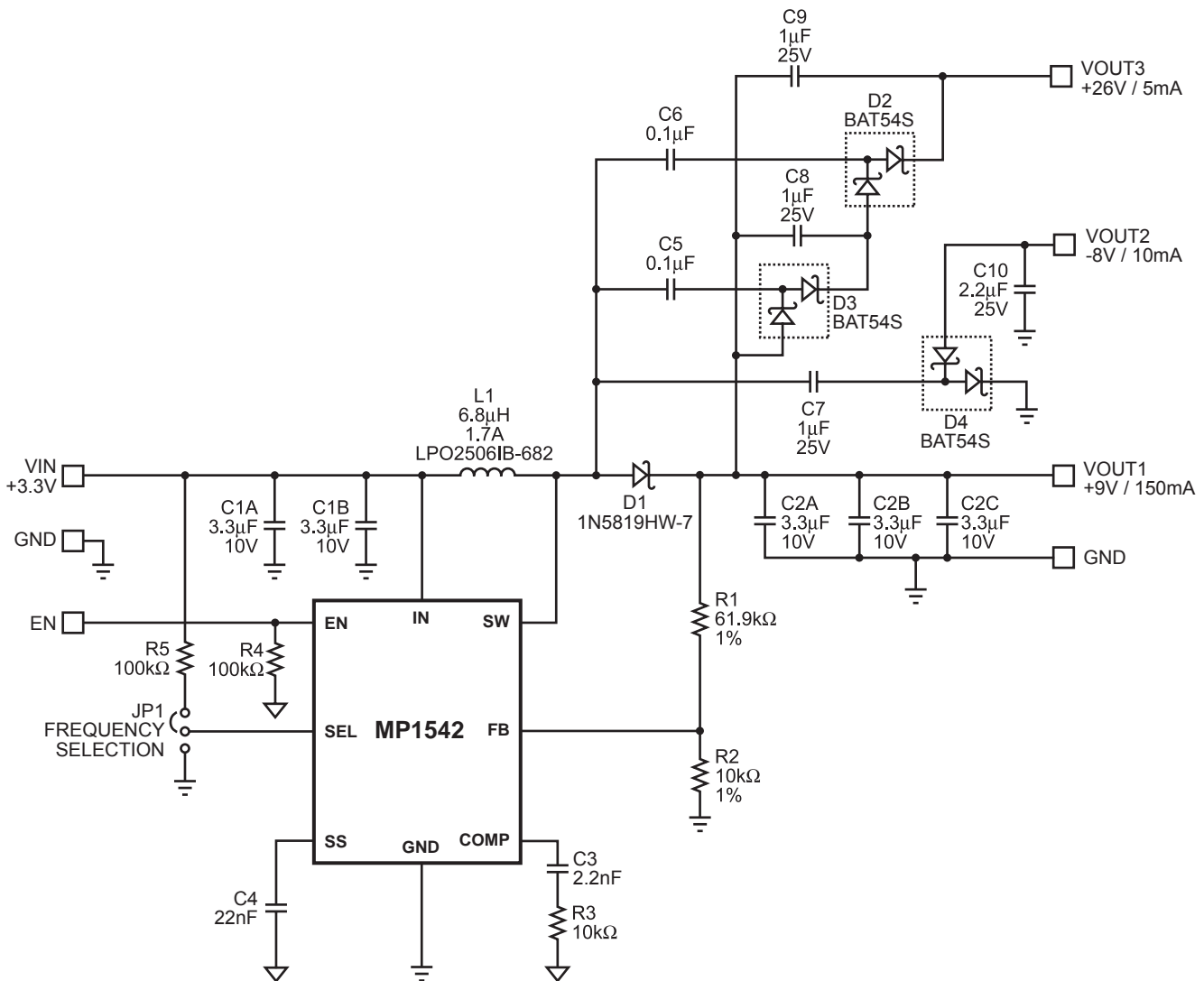

Figure 1—TFT LCD Bias Supply (1.2mm Maximum Height)

Circuit Description and Performance

Figure 1 shows a TFT LCD bias supply generating 9V, 26V and -8V outputs with the MP1542. The circuit consists of a 9V step-up converter, a 2x charge pump to obtain 26V, and a 1x charge pump to obtain -8V.

The input voltage can be set to 3.3V or 5V. The switching frequency can be set to 1.3MHz or 700KHz by pulling the FSEL pin high or low, respectively. 1.3MHz operation makes it possible to use all components under 1.2mm, including the power inductor, and still deliver reasonably large power.

The soft-start can be programmed with capacitor C4. Transient response can also be adjusted with capacitor C3 and resistor R3.

Figure 2 shows the efficiency of the main step-up converter under different load currents and input voltages. Efficiencies greater than 90% can be easily achieved even with small, low profile components.

Figures 3 and 4 show transient responses at 3.3V and 5V input. Load regulation on -8V and 26V outputs is shown in Figures 5 and 6.

If tighter regulation is required, a linear regulator can be used on these rails.

Figure 7 shows the start-up waveform for this bias supply.

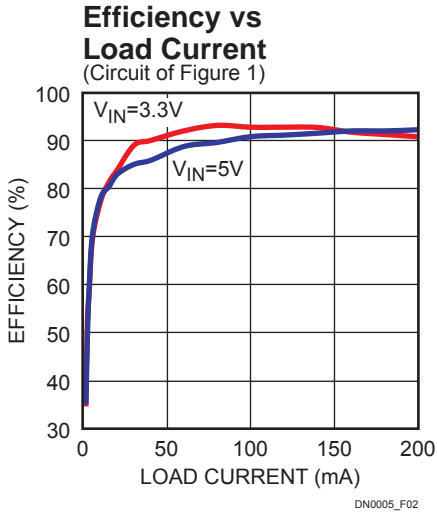

Figure 2—Efficiency Curve

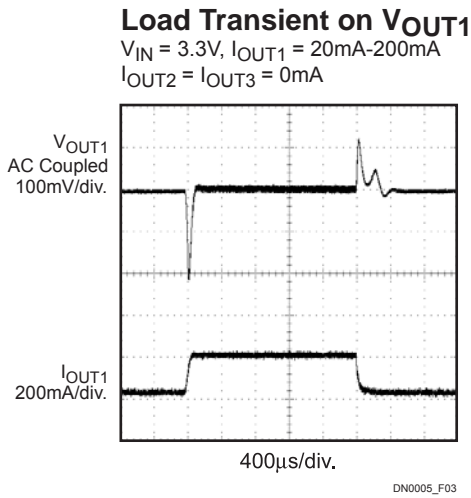

Figure 3—Transient Response for $V_{IN} = 3.3V$

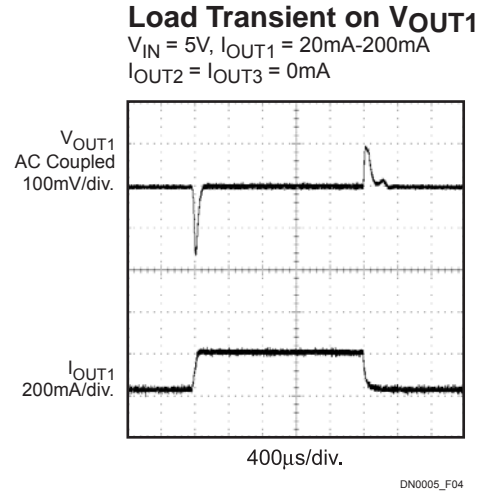

Figure 4—Transient Response for $V_{IN} = 5V$

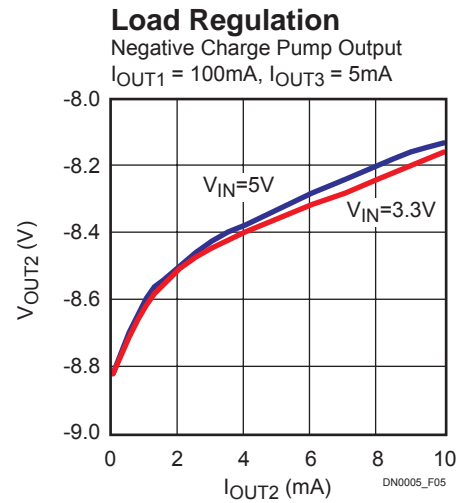

Figure 5—Load Regulation on -8V Output

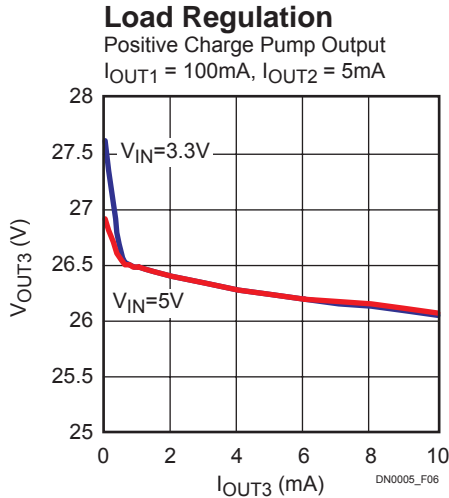

Figure 6—Load Regulation on 26V Output

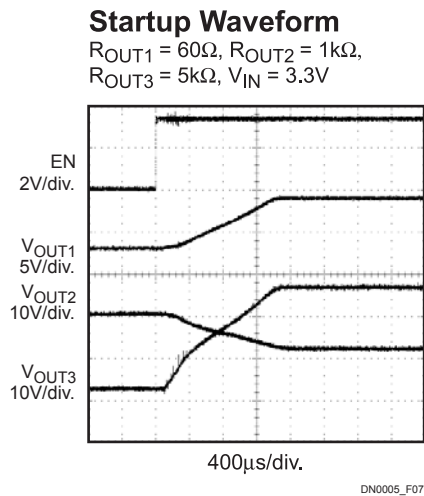

Figure 7—Startup

Conclusion

The MP1542 has the best set of features to implement a high performance, low profile, multi-output TFT LCD bias supply in addition to being well suited for generic step-up applications.

NOTICE: The information in this document is subject to change without notice. Please contact MPS for current specifications. Users should warrant and guarantee that third party Intellectual Property rights are not infringed upon when integrating MPS products into any application. MPS will not assume any legal responsibility for any said applications.